



**mpc**  
METODICKO-PEDAGOGICKÉ CENTRUM

**VZDELÁVANÍM  
PEDAGOGICKÝCH ZAMESTNANCOV  
K INKLÚZII MARGINALIZOVANÝCH  
RÓMSKYCH KOMUNÍT**



Moderné vzdelávanie pre vedomostnú spoločnosť / Projekt je spolufinancovaný zo zdrojov EÚ

Kód ITMS: 26130130051

číslo zmluvy: OPV/24/2011

**Metodicko – pedagogické centrum**

**Národný projekt**

**VZDELÁVANÍM PEDAGOGICKÝCH ZAMESTNANCOV  
K INKLÚZII MARGINALIZOVANÝCH RÓMSKYCH KOMUNÍT**

**MGR. Iveta Rennerová**

**ZÁBAVNÁ ANGLIČTINA – 1. časť**

**Vydavateľ:** Metodicko-pedagogické centrum,  
Ševčenkova 11, 850 01  
Bratislava

**Autor UZ:** Mgr. Iveta Rennerová

**Kontakt na autora UZ:** ZŠ s MŠ Lipovce,  
Lipovce 125, 082 36  
zssmslipovce@gmail.com

**Názov:** Zábavná angličtina – 1. časť

**Rok vytvorenia:** 2014

**Oponentský posudok  
vypracoval:** Mgr. Gabriela Pavelková

**ISBN 978-80-8052-829-4**

Tento učebný zdroj bol vytvorený z prostriedkov projektu Vzdelávaním pedagogických zamestnancov k inklúzii marginalizovaných rómskych komunít. Projekt je spolufinancovaný zo zdrojov Európskej únie.

Text neprešiel štylistickou ani grafickou úpravou.

<b>Obsah: My classroom</b>	<b>4</b>
<b>My classroom</b>	<b>5</b>
<b>My classroom</b>	<b>6</b>
<b>Colours and shapes</b>	<b>7</b>
<b>Colours and shapes</b>	<b>8</b>
<b>My things</b>	<b>9</b>
<b>My things</b>	<b>10</b>
<b>My things</b>	<b>11</b>
<b>Zdroje</b>	<b>12</b>

# 1. MY CLASSROOM

1. Point, say things in the classroom. Ukáź, pomeňuj veci v triede.



Find , circle and colour things in the classroom. Nájdí, zakrúžkuj a vyfarbi.

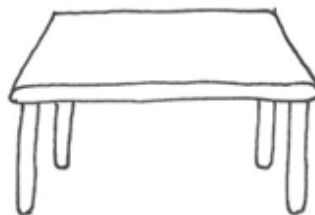
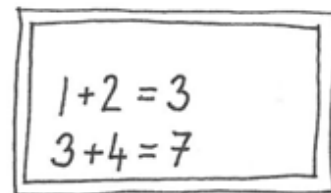
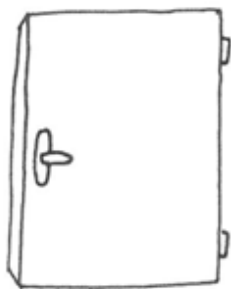

**2. How many? Count, cut and make your school. Draw your self and your friends. Koľko? Počítaj, strihaj a urob si školu. Dokresli seba a svojich**

priateľov. Ulož si ju do svojho portfólia.

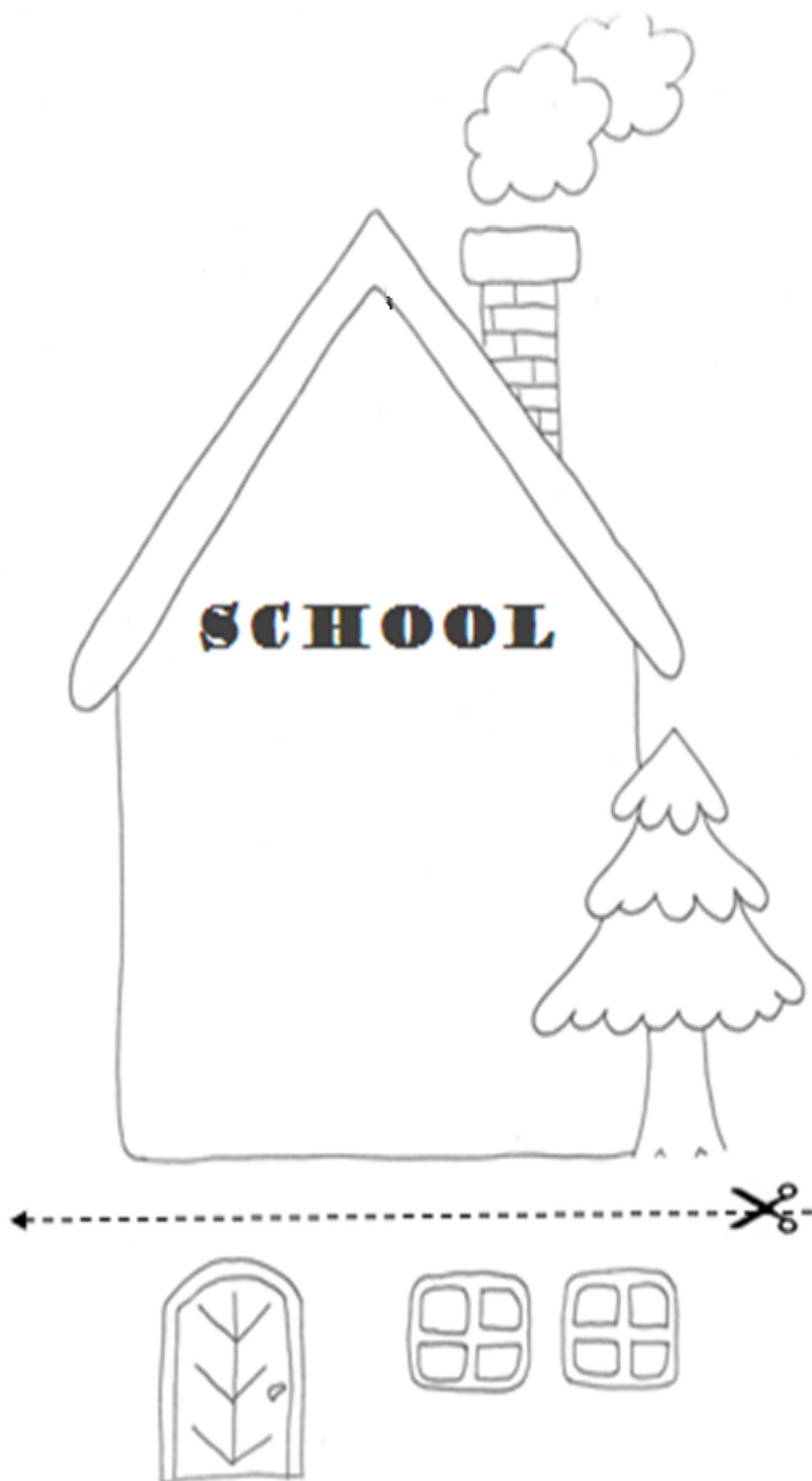

3. Much and say. Spoj a pomenuj.



## 2. COLOURS AND SHAPES

1. Trace, say and colour. Obťiahni, pomenuj a vyfarbi.

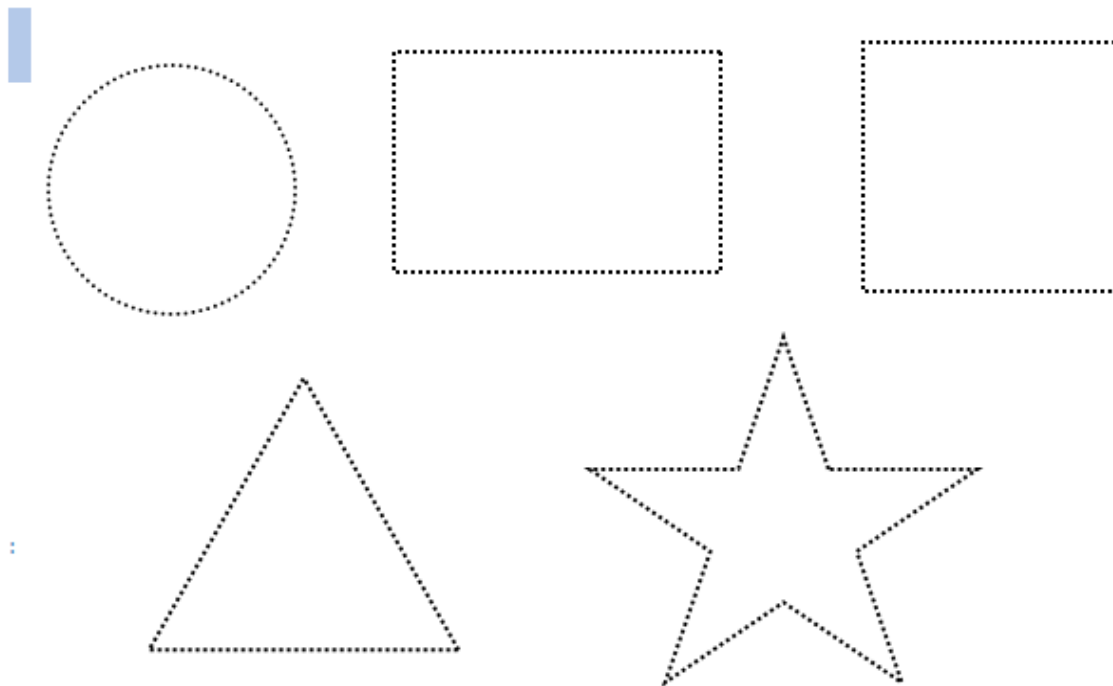

2. Colour and say. Vyfarbi a pomenuj:



3. Colour triangles red and find the bees house. Vyfarbi červenou trojuholníky a nájdí včelí domček.

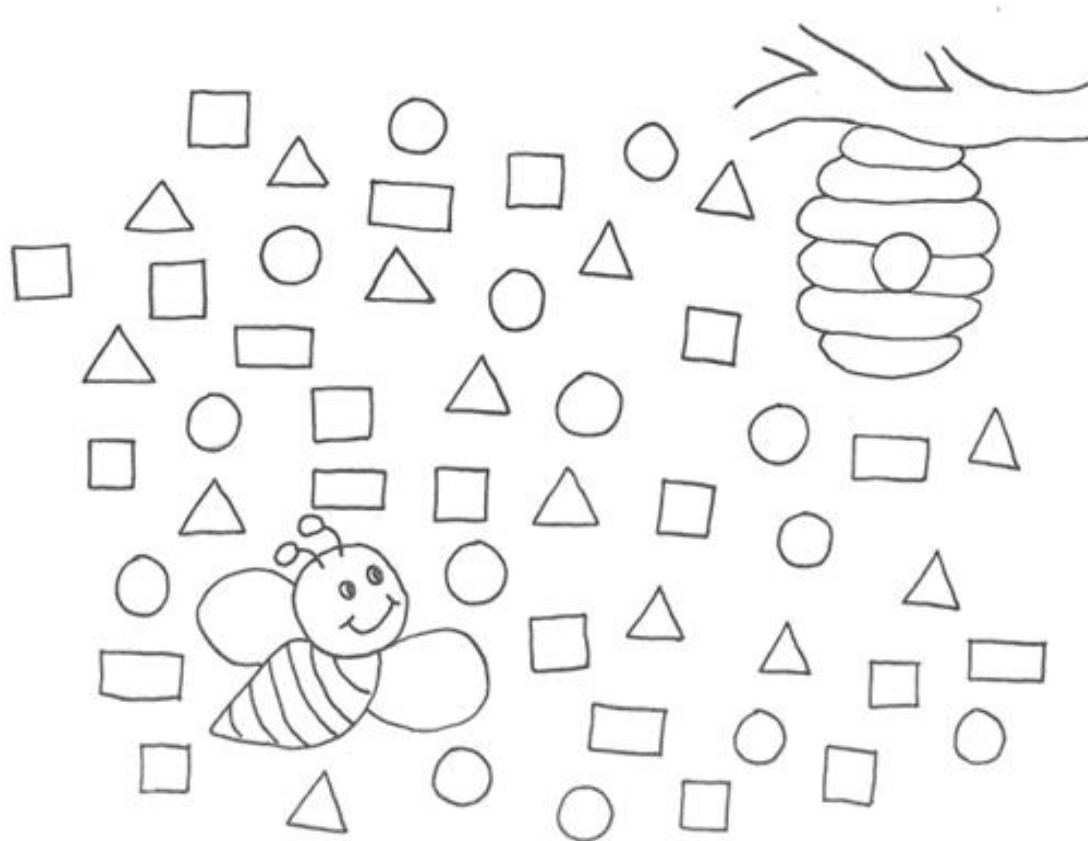

4. Match. (Spájaj. Na ktorý geometrický tvar sa obrázok podobá.)

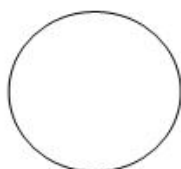



### 3. MY THINGS

1. Find, say and colour. (Nájdí na obrázku, pomenuj a vyfarbi.)



2. Much and colour. (Spoj predmety so správnym číslom a varbi.)

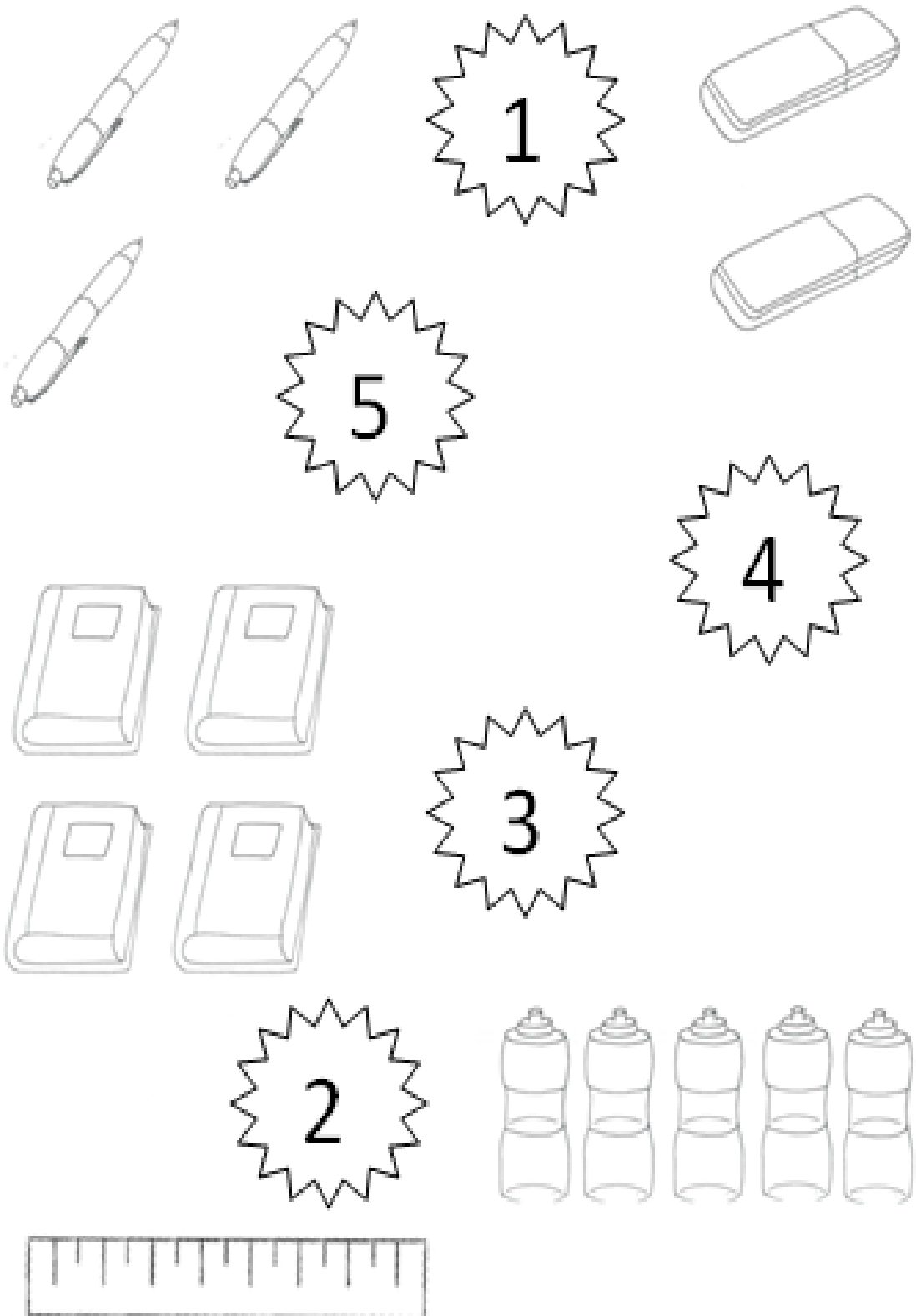

3. Make your own pencilbox. Colour and cut out school things and glue them into the pencil box. (Vytvor svoj vlastný peračník.)

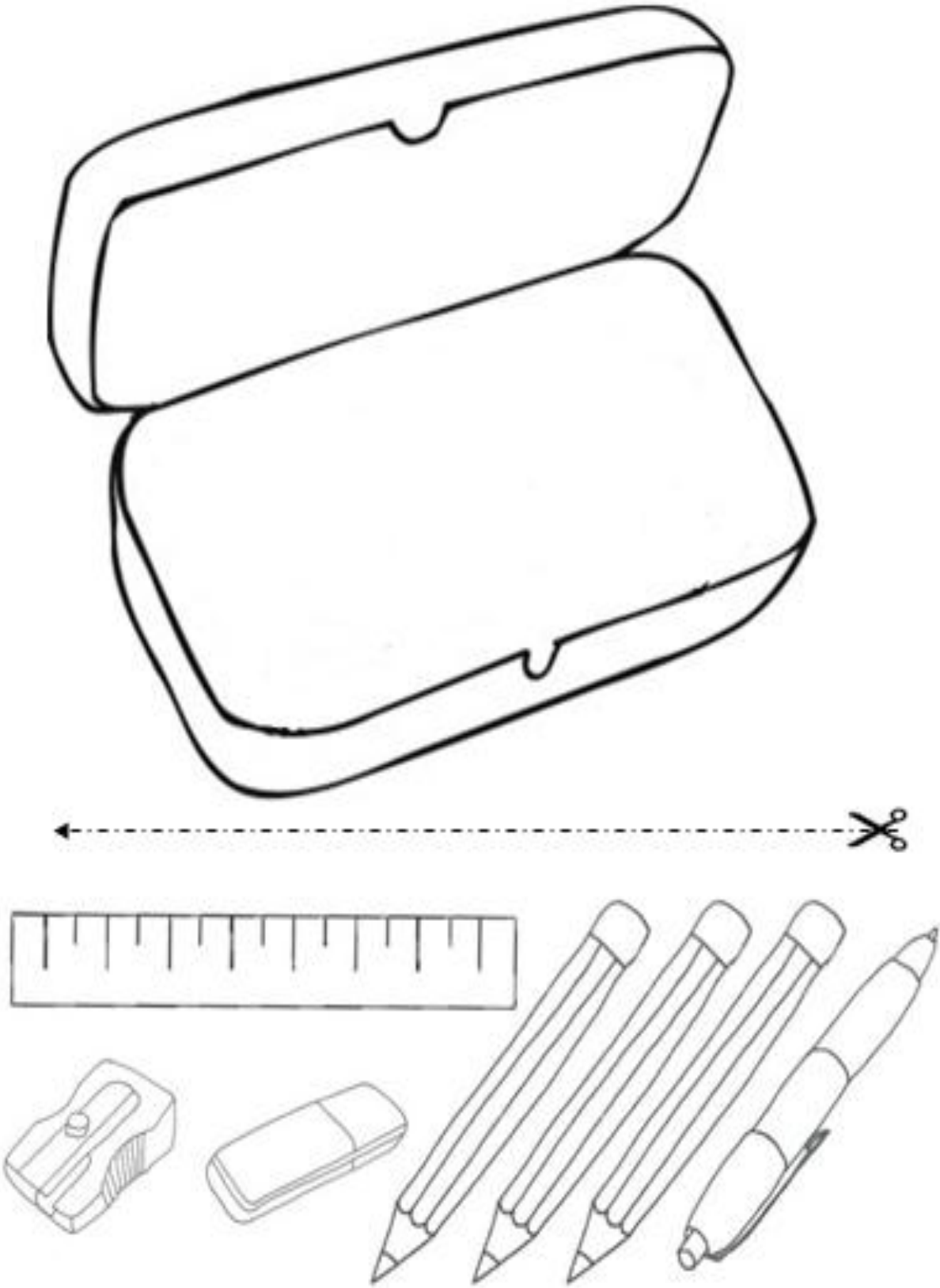

**Zdroj: ActivInspire - Studio**